

## INKEPINGENFREES RECHT

DEF.402.68

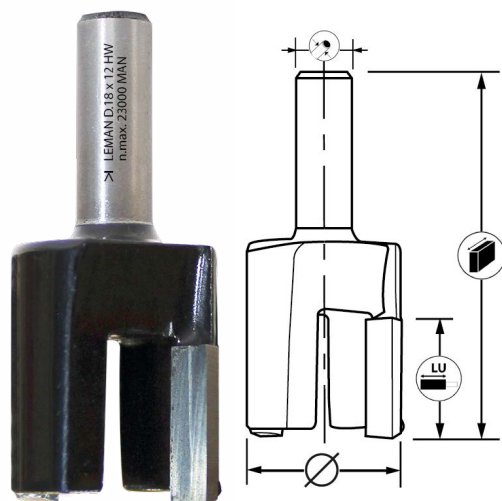

Ideaal voor

Massief hout



**CLASSIC**  
Kenmerken

- Maken van inkepingen voor het plaatsen van scharnieren, hengsels, enz.

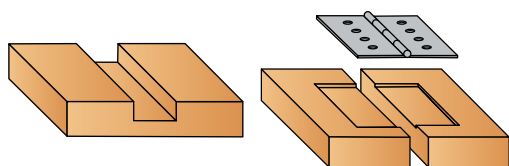

HM

EN847-1



Raadpleeg onze  
8000 referenties  
op onze website.

Productblad

## Technische gegevens

Diameter	Lengte nuttig	Diameter staart/as	Lengte	Nummer van bezuinigingen	Referentie	Verpakking	Streepjescode
12	12	6	38	2	4026.712.00	1	3661589051004
13	12	6	38	2	4026.713.00	1	3661589050991
14	12	6	38	2	4026.714.00	1	3661589050984
15	12	6	38	2	4026.715.00	1	3661589050977
16	12	6	38	2	4026.716.00	1	3661589050960
18	12	6	38	2	4026.718.00	1	3661589050953
20	12	6	38	2	4026.720.00	1	3661589050946
22	12	6	38	2	4026.722.00	1	3661589050939
25	12	6	38	2	4026.725.00	1	3661589050922

U vindt alle referenties in onze catalogus of op onze website.